

REVISION		
REV	DATE	DESCRIPTION
A	6/28/04	INITIAL
B	2/08/13	CHANGE P/N & NEW TEMPLATE

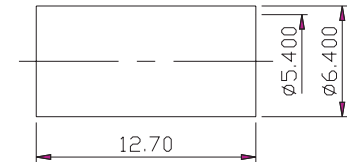
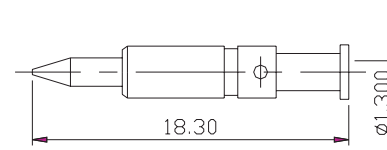
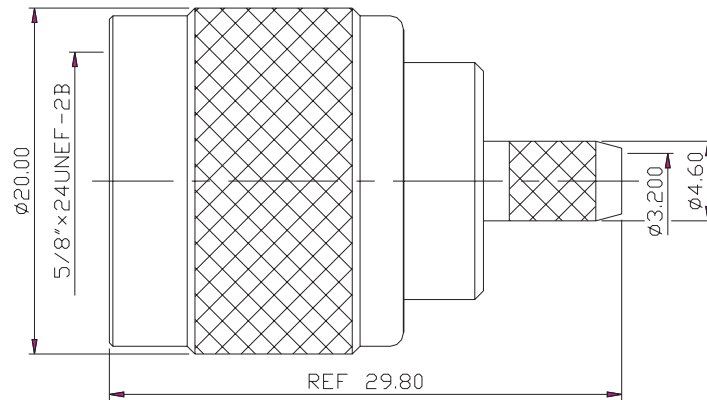
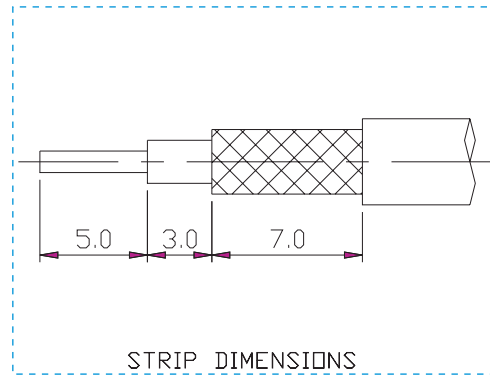

7.	SHELL	BRASS	1	NICKEL
6.	FERRULE	BRASS	1	NICKEL
5.	WASHER	BRASS	1	NICKEL
4.	SLEEVE	BRASS	1	NICKEL
3.	INSULATION	TEFLON	1	NONE
2.	PIN	BRASS	1	GOLD
1.	BODY	BRASS	1	NICKEL
NO.	DESCRIPTION	MATERIAL	Q' TY	FINISH

TOLERANCE .X +/- 0.2 .XX +/- 0.1 .XXX +/- 0.05 ANGLE +/- 0.5	UNITS mm		DRAWN BY: 	CHECKED BY: 	APPROVED BY: 	CAD FILE 11-11L1-TGN	TCC INDUSTRIES INC. 7050 Village Drive unit E, Buena Park, CA 90621-2282 Tel. 714.523.8885 - FAX. 714.562.0888 E-Mail: info@tcinc.com Website: www.tcinc.com
	SCALE NTS		SIZE A	PROPRIETARY AND CONFIDENTIAL THE INFORMATION IN THIS DRAWING IS THE SOLE PROPERTY OF TCC INDUSTRIES, INC. ANY REPRODUCTION IN PART OR AS A WHOLE WITHOUT THE WRITTEN PERMISSION OF TCC INDUSTRIES, INC. IS PROHIBITED.			
SHEET 1 OF 1							